

# Enhancing the User Experience with the Sensory Effect Media Player and AmbientLib

Markus Walzl, Benjamin Rainer, Christian Timmerer, and Hermann Hellwagner

Alpen-Adria-Universität Klagenfurt, Inst. of Information Technology  
Multimedia Communication Group, Universitätsstraße 65-67  
Klagenfurt, Austria  
firstname.lastname@itec.uni-klu.ac.at

**Abstract.** Multimedia content is increasingly used in every area of our life. Still, each type of content only stimulates the visual and/or the hearing system. Thus, the user experience depends only on those two stimuli. In this paper we introduce a standard which offers the possibility to add additional effects to multimedia content. Furthermore, we present a multimedia player and a Web browser plug-in which uses this standard to stimulate further senses by using additional sensory effects (i.e., wind, vibration, and light) to enhance the user experience resulting in a unique, worthwhile sensory experience.

**Keywords:** MPEG-V, User Experience, Sensory Experience, Media Player, Ambient, World Wide Web.

## 1 Introduction

Each day a vast amount of multimedia content is consumed through distribution channels such as Blu-Ray discs or the Internet. All traditional multimedia content (i.e., combinations of video, audio, text, and image) has in common that it only stimulates the human visual and/or hearing system. Thus, research commenced which introduces and evaluates the enhancement of multimedia content with additional stimuli (e.g., olfaction, mechanoreception, thermoreception) [1, 2].

As this research area gained a lot of interest, the Motion Picture Experts Group (MPEG) initiated the work on the MPEG-V – Media Context and Control [3] standard. Part 3 of this standard is referred to as Sensory Information (SI) and provides the possibility to enrich available multimedia content with additional effects (e.g., wind, vibration, light, scent) for enhancing the user experience. Such effects are described by so-called *Sensory Effect Metadata* (SEM) descriptions providing information such as the type of effect, intensity of the effect, playback time, etc.

We [4-6] and also others [7, 8] started using and evaluating MPEG-V in various application areas (e.g., multimedia playback, broadcasting, World Wide Web). In the remainder of this paper we describe our implementation (Section 2) and demonstrator (Section 3).

## 2 Sensory Effect Media Player and AmbientLib

The *Sensory Effect Media Player* (SEMP) is a Windows-based media player which offers the possibility to load videos and SEM descriptions. These descriptions are processed, synchronized with the video, and rendered on appropriate devices (e.g., ambient lights, vibration devices, fans). Currently the player supports the amBX system [9] consisting of two fans, two “light” speakers (left and right) with a subwoofer, a wall-washer unit, and a vibration panel. We used the freely available SDK to program the amBX system for enhancing the user experience while watching videos. The architecture of SEMP is illustrated in Fig. 1 (a). SEMP can automatically extract color information from the currently rendered frame and display the color on the amBX lights.

Since more and more multimedia content is available on the Internet through different portals (e.g., YouTube and Vimeo), we started to work on a browser plug-in (called *AmbientLib*) which enables the sensory experience in the Web browser. The current version of the plug-in supports all major browsers (i.e., Opera, Google Chrome, Safari, Mozilla Firefox, Internet Explorer) and is easy to install. *AmbientLib* handles light effects the same way as SEMP but with the difference that the videos are embedded in Web sites. The plug-in is able to handle Flash videos and videos provided through the HTML5 video tag. Furthermore, if the plug-in detects an available SEM description, it also provides wind and vibration effects accordingly. Fig. 1 (b) presents the architecture of *AmbientLib*.

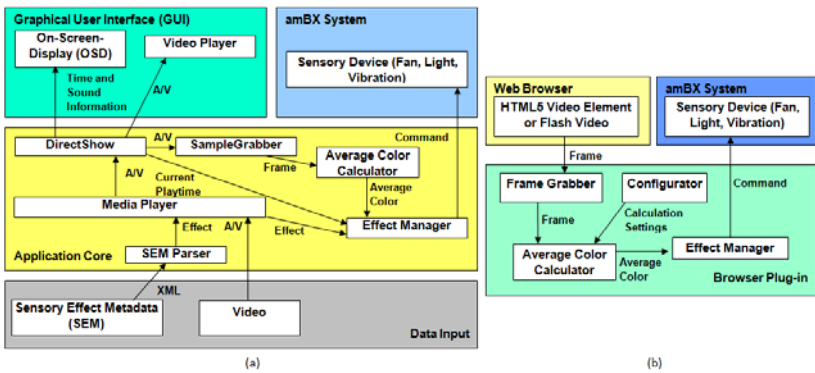

Fig. 1. Architectures of the Sensory Effect Media Player (a) and the AmbientLib Plug-in (b)

## 3 Demonstration

In our demonstration, we will present both SEMP and *AmbientLib*. First, we will present videos with and without sensory effects (i.e., light, vibration, and wind) by using SEMP. Second, we will demonstrate a number of videos accompanied by SEM descriptions using *AmbientLib*.

Participants will be able to try SEMP and *AmbientLib*. We believe that the possibility to experience the sensory effects first hand will trigger discussions on this research. A small example of the demonstration is depicted in Fig. 2 (the fan in action is depicted on the upper right corner).



**Fig. 2.** Enhanced Video Playback with SEMP

**Acknowledgments.** This work was supported in part by the European Commission in the context of the ALICANTE project (FP7-ICT-248652).

## References

1. Chang, A., O’Sullivan, C.: Audio-haptic feedback in mobile phones. In: ACM Conference on Human Factors in Computing Systems (CHI 2005), CHI 2005 Extended Abstracts on Human Factors in Computing Systems, Portland, OR, USA, pp. 1264–1267 (2005)
2. Ghinea, G., Ademoye, O.A.: Olfaction-enhanced multimedia: perspectives and challenges. In: Multimedia Tools and Applications, pp. 1–26 ( August 2010)
3. ISO/IEC 23005-3: Information technology – Media context and control – Part 3: Sensory information (June 2011)
4. Watl, M., Timmerer, C., Hellwagner, H.: A Test-Bed for Quality of Multimedia Experience Evaluation of Sensory Effects. In: 1st Int’l. Workshop on Quality of Multimedia Experience (QoMEX 2009), San Diego, USA (2009)
5. Watl, M., Timmerer, C., Hellwagner, H.: Increasing the User Experience of Multimedia Presentations with Sensory Effects. In: 11th Int’l. Workshop on Image Analysis for Multimedia Interactive Services (WIAMIS 2010), Desenzano del Garda, Italy (2010)
6. Watl, M., Timmerer, C., Hellwagner, H.: Improving the Quality of Multimedia Experience through Sensory Effects. In: 2nd Int’l. Workshop on Quality of Multimedia Experience (QoMEX 2010), Trondheim, Norway (2010)
7. Choi, B.S., Joo, S., Lee, H.: Sensory Effect Metadata for SMMD Media Service. In: 4th Int’l Conf. on Internet and Web Applications and Services (ICIW 2009), Venice/Mestre, Italy, pp. 649–654 (2009)
8. Yoon, K., Choi, B., Lee, E., Lim, T.: 4-D Broadcasting with MPEG-V. In: 12th Workshop on Multimedia Signal Processing (MMSP) 2010, Saint-Malo, France, pp. 257–262 (2010)
9. amBX UK Ltd, <http://www.ambx.com>